

BALCONY VIEWS magazine

Media Information Kit



ISSN 2040-7955 (Print)
ISSN 20407963 (Online)

What is Balcony Views?

- A new magazine launched in 2010, published by Balcony Systems Ltd in association with NH Publishing Ltd.
- A new magazine for design and build professionals
- A showcase for innovative design and build solutions
- A beautifully-designed full colour glossy A4 publication in stunning landscape format to highlight panoramic visual presentations

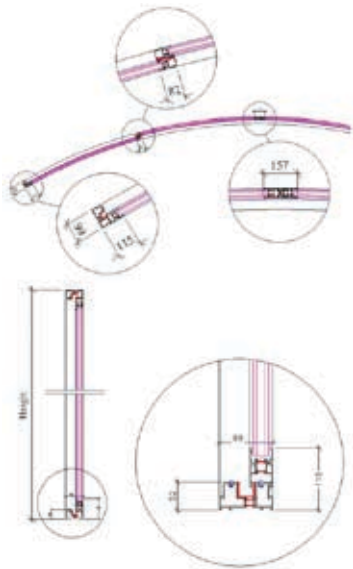
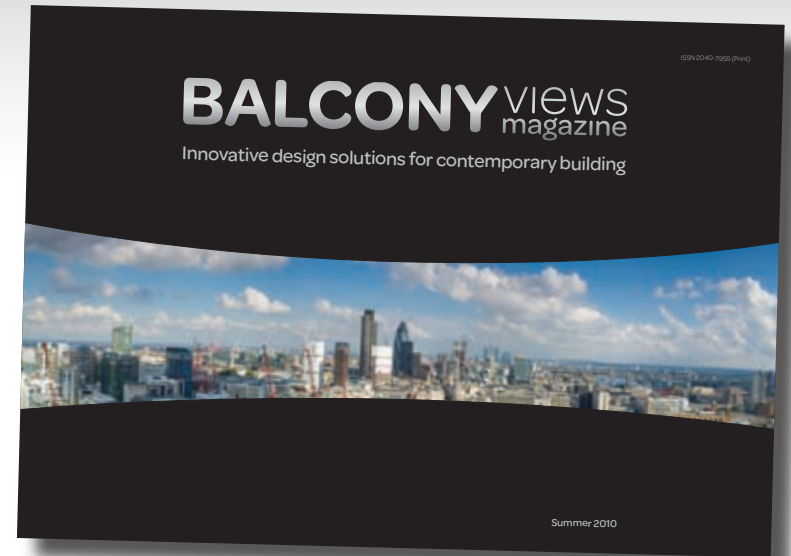

What's in Balcony Views?

- Features – the latest design and product innovations for new build, regeneration & renewal and self build
- Product Showcase – suppliers unveil new and innovative products and services
- News in brief
- 'How-to' articles on installation, design incorporation and finishing
- Columns – Comment and opinions from expert industry insiders
- Customer case studies
- Diary Dates – the essential guide to design & build events, courses and seminars

Readership

Print run 26,000 copies

Mailout* 16,205 copies comprising:
8,361 Architects
2,741 Building Contractors
5,103 Property Developers

Distribution circa 10,000 copies

New Balcony Systems enquiries

Grand Designs Exhibition

National Self Build Centre – permanent display

Balcony Views Digital Hosted at www.balconyViews.co.uk

*Mailout from data held on file by Balcony Systems - valid as of 01/09/2010



Publishing Partnerships

Balcony Systems Ltd invites selected suppliers to join as Balcony Views Publishing Partners.

Platinum Partner – 4 page spread

A stunning 3 page feature including images of your products or services accompanied by a one page advertisement.

Gold Partner – 2 page spread

A superb one page editorial feature facing a one page company advertisement

Publishing Partner editorial, images and advertisement are client supplied. For in-house commissioning using Balcony Views' established network of expert designers, journalists and photographers rates are available on request.

Platinum Partner	£2,235
Gold Partner	£1,435
Full page	£875
Half page	£445
Quarter Page	£235
Product Showcase	£2.30 per word and £65 per image or logo
Diary Dates	£50 for full listing including web link

Inside front cover and outside back cover rates available on request

Quoted rates are ex-VAT

February 2011 - Issue 2

Booking & Copy deadline 14th January 2011

Balcony Views is published twice per annum

editorial & sales:

Lesley Woodcraft
lesley@balconette.co.uk
01342 410 411

Full Page

297mm wide x 210mm tall
(3mm bleed and 3mm offset crops)
Type area 273mm wide x 186mm tall

Double Page Spread

594mm wide x 210mm tall
(3mm bleed and 3mm offset crops)

Half Page Portrait

136.5mm wide x 186mm tall

Half Page Landscape

273mm wide x 93mm tall

Quarter Page Landscape

136.5mm wide x 93mm tall

Quarter Page Portrait

68.25mm wide x 186mm tall

Acceptable artwork format:

PDF, TIFF, EPS OR JPEG, 300dpi or greater
email to info@balconyviews.co.uk